

Frame system assembly

Right side view 3 rails system

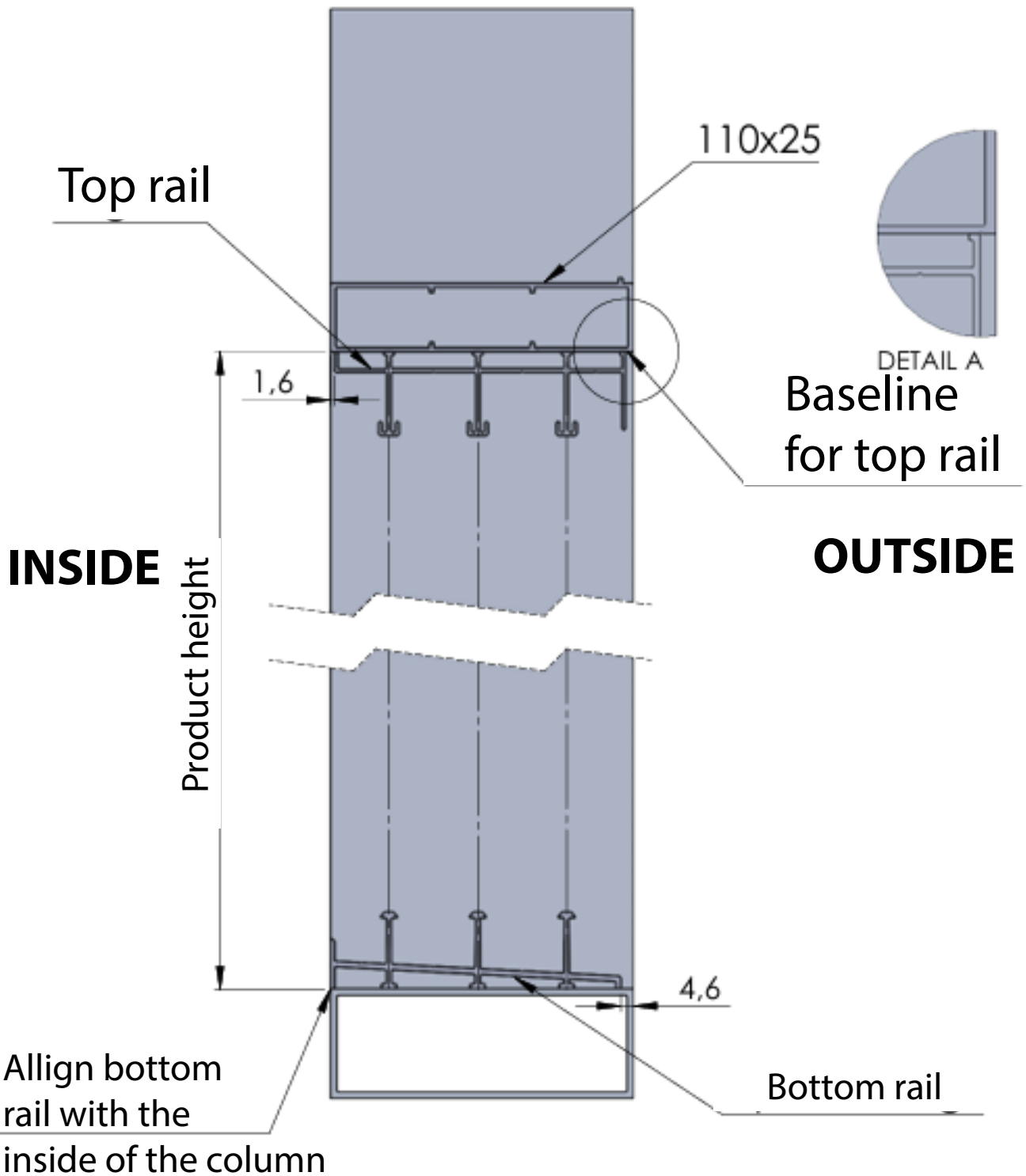

Right side view 2 rails system

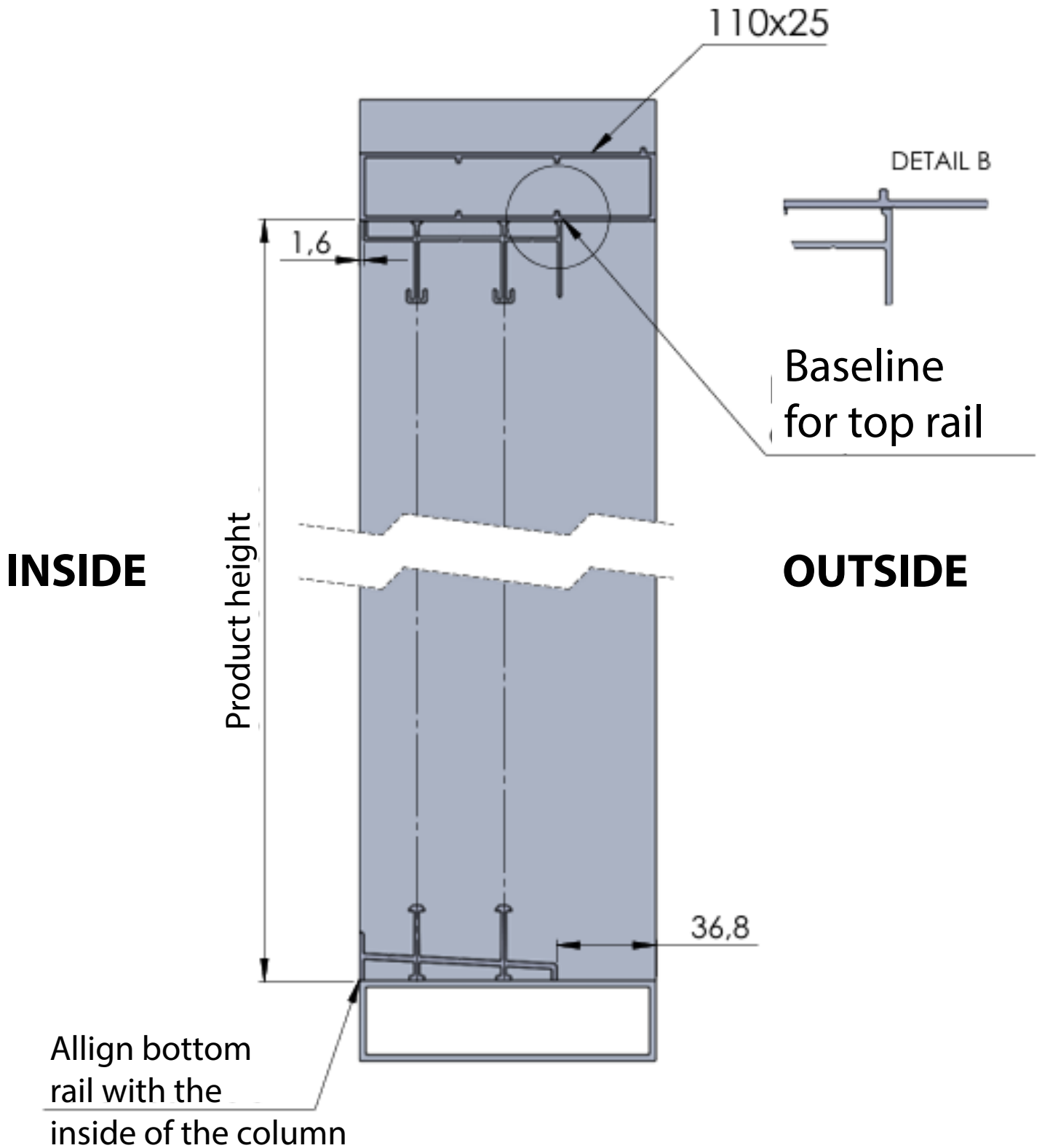

Right side view 4 rails system

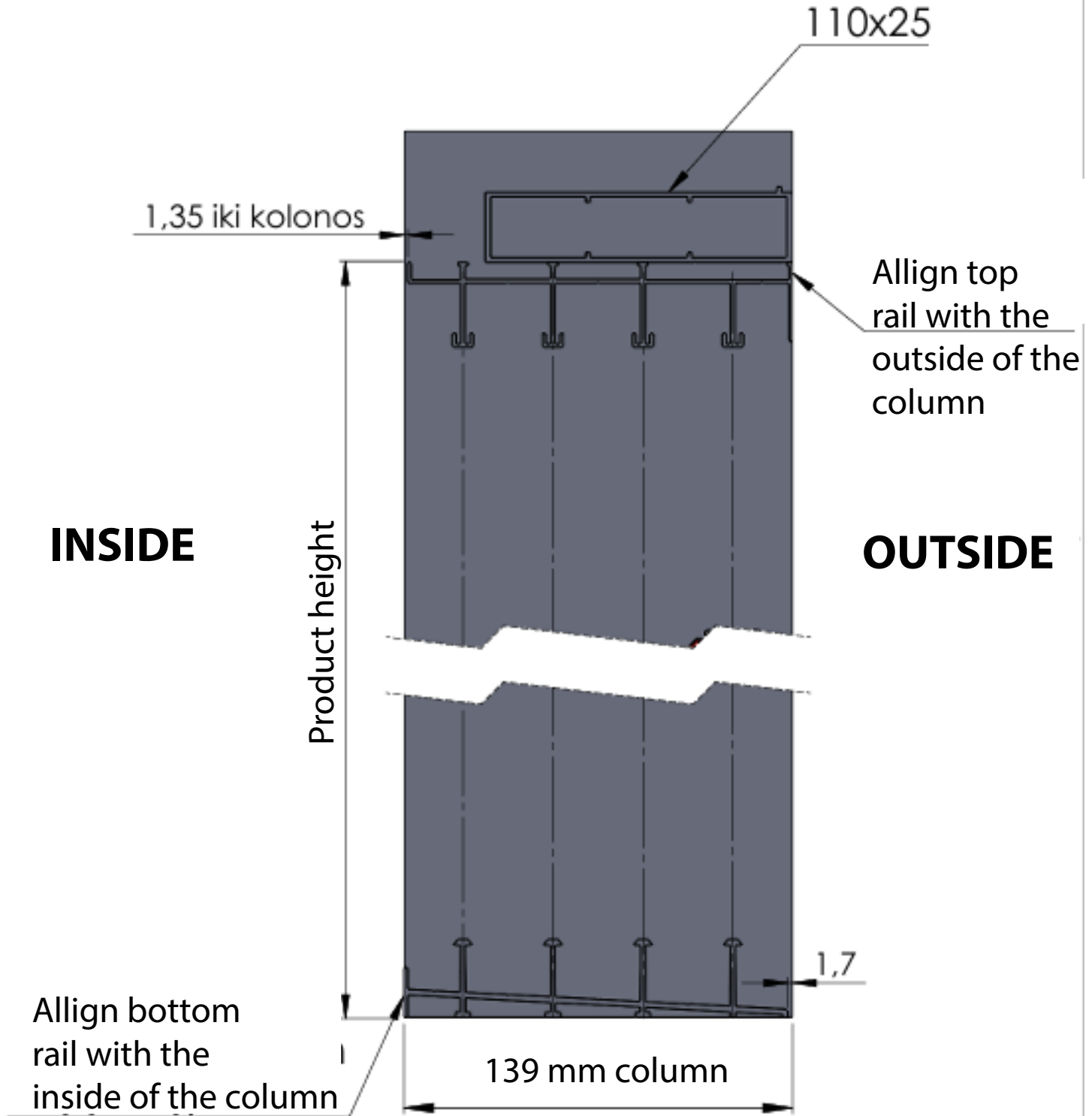

Product height you can find in client paper (marked red) :

Client	0		Ref No.:
Address	0		
Colour	RAL7016 Coatex		
V1	Length (mm)	3000	
	Height (mm)	2200	
	Glazing	H, mm	L, mm
	4 mm gr. Skaidrus stiklas	2046	919

Vertical profile RV1 assemble

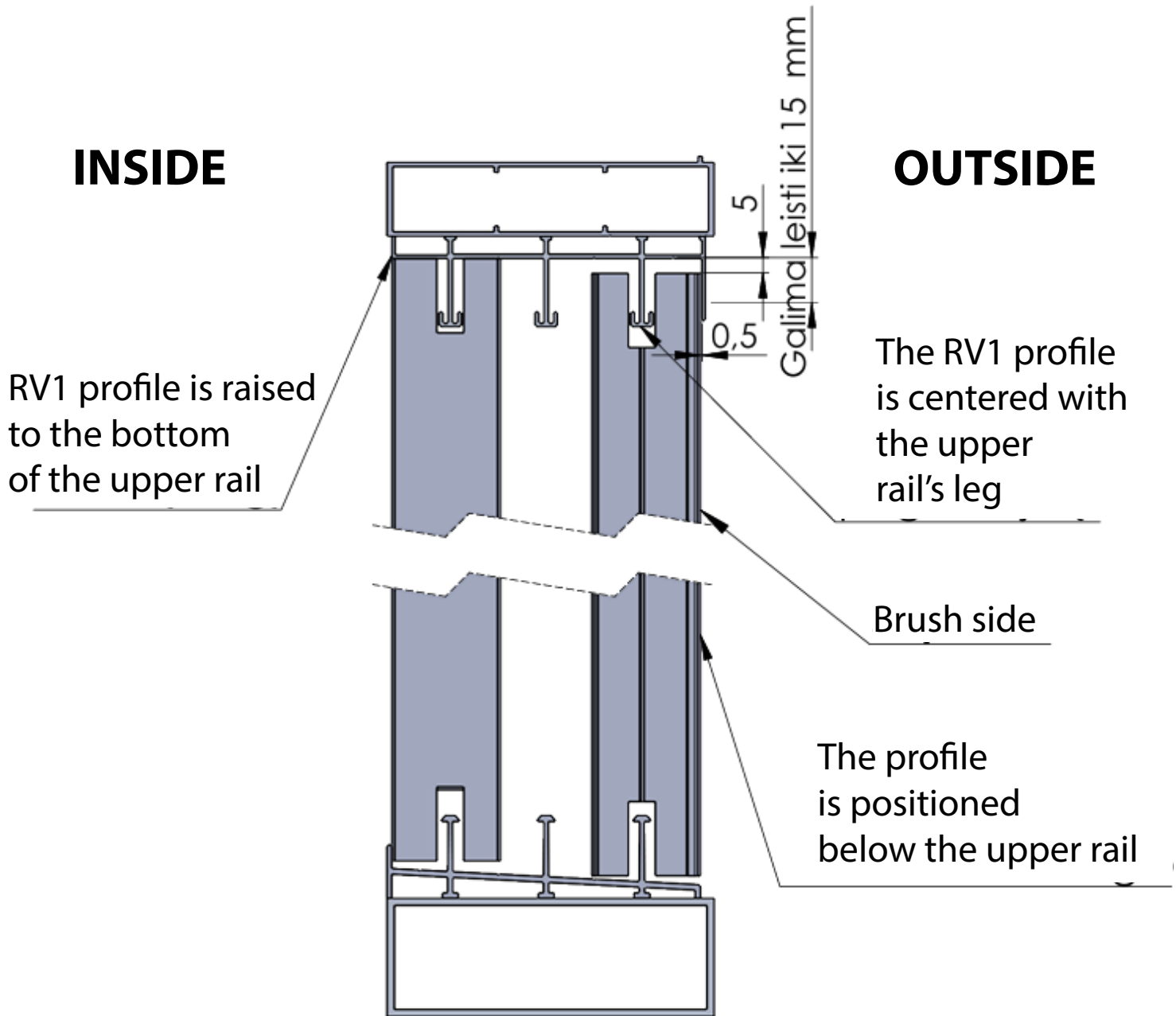

OUTSIDE

INSIDE

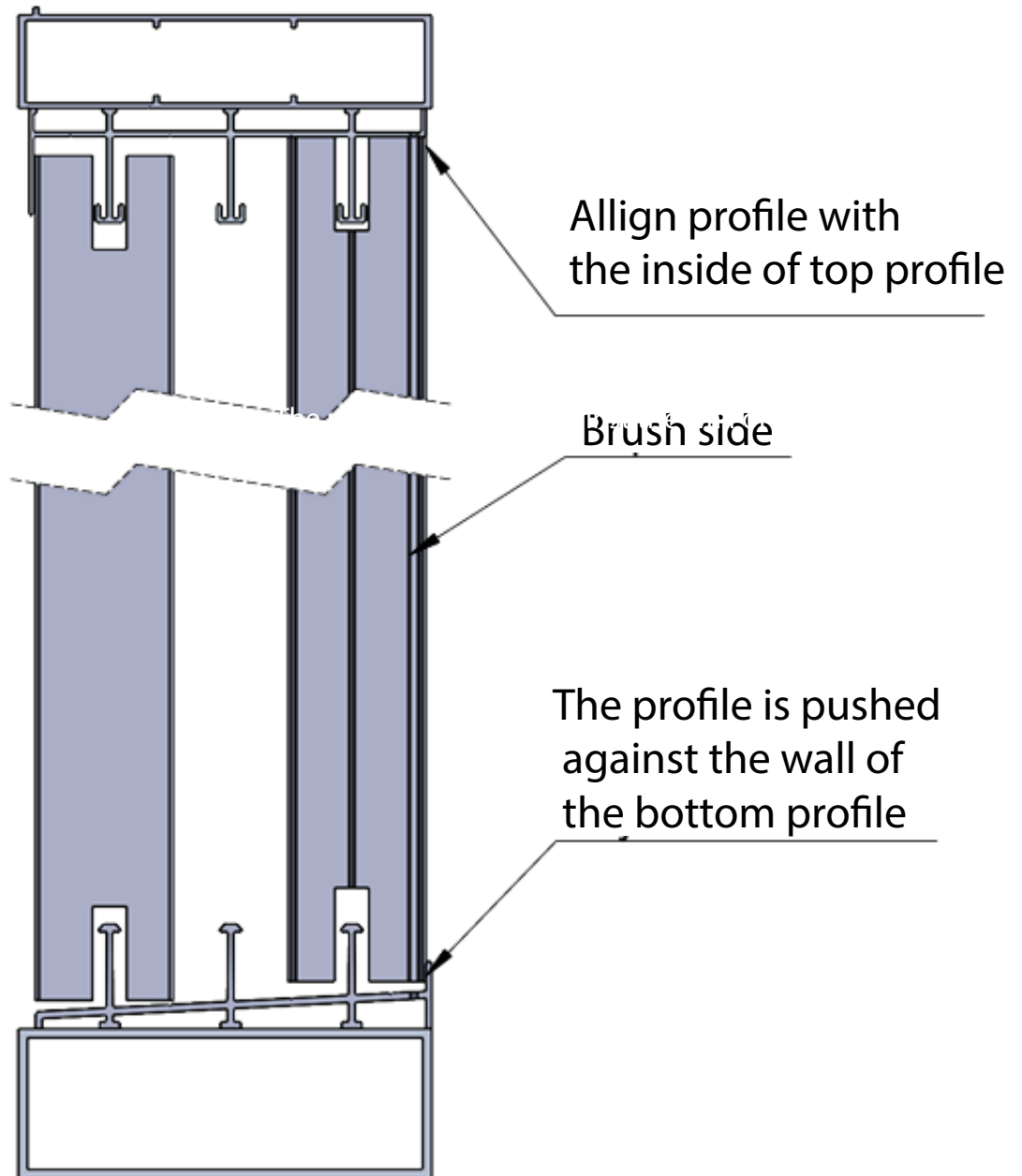

OUTSIDE

INSIDE

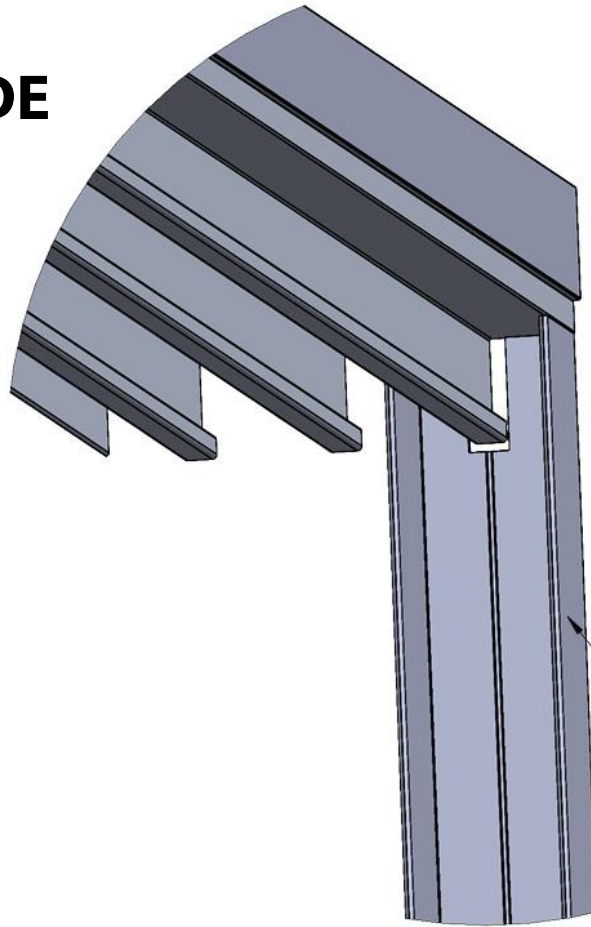

Brush

INSIDE

OUTSIDE

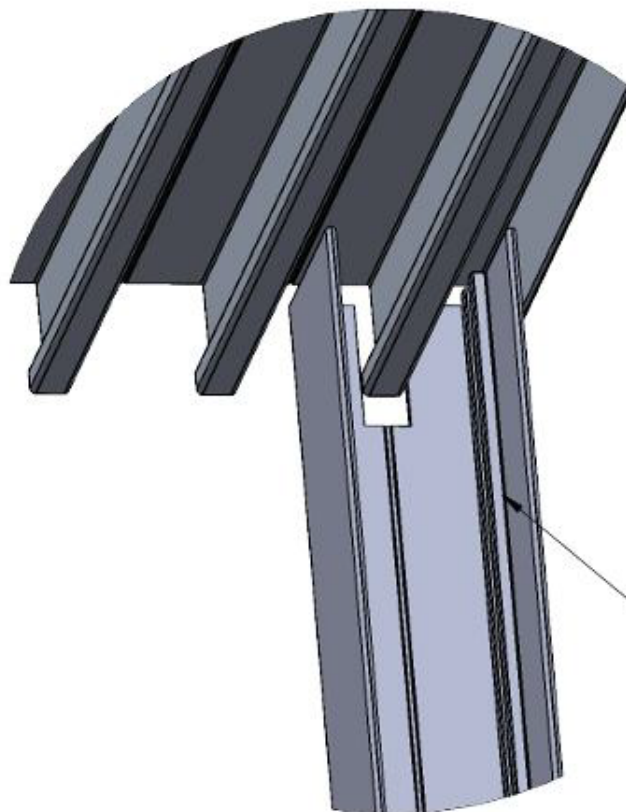

Brush

You can always check the brush side of the RV1 profile in the layouts provided on the client sheet.

For example:

TOP VIEW

Outside

Brush

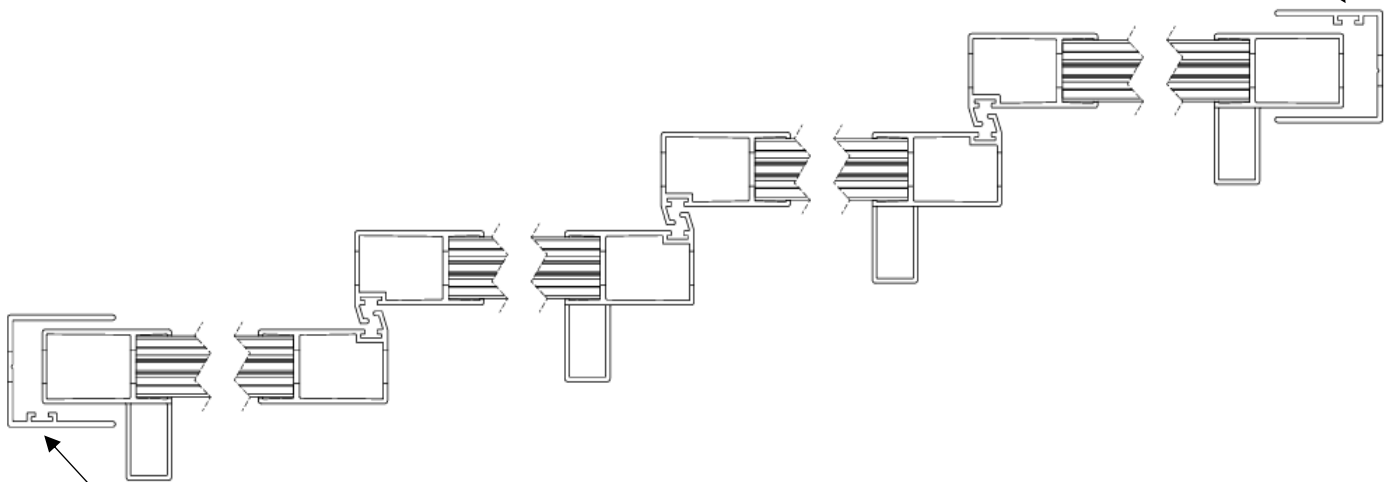

Inside

Brush

PLUNGER LOCKS ASSEMBLY

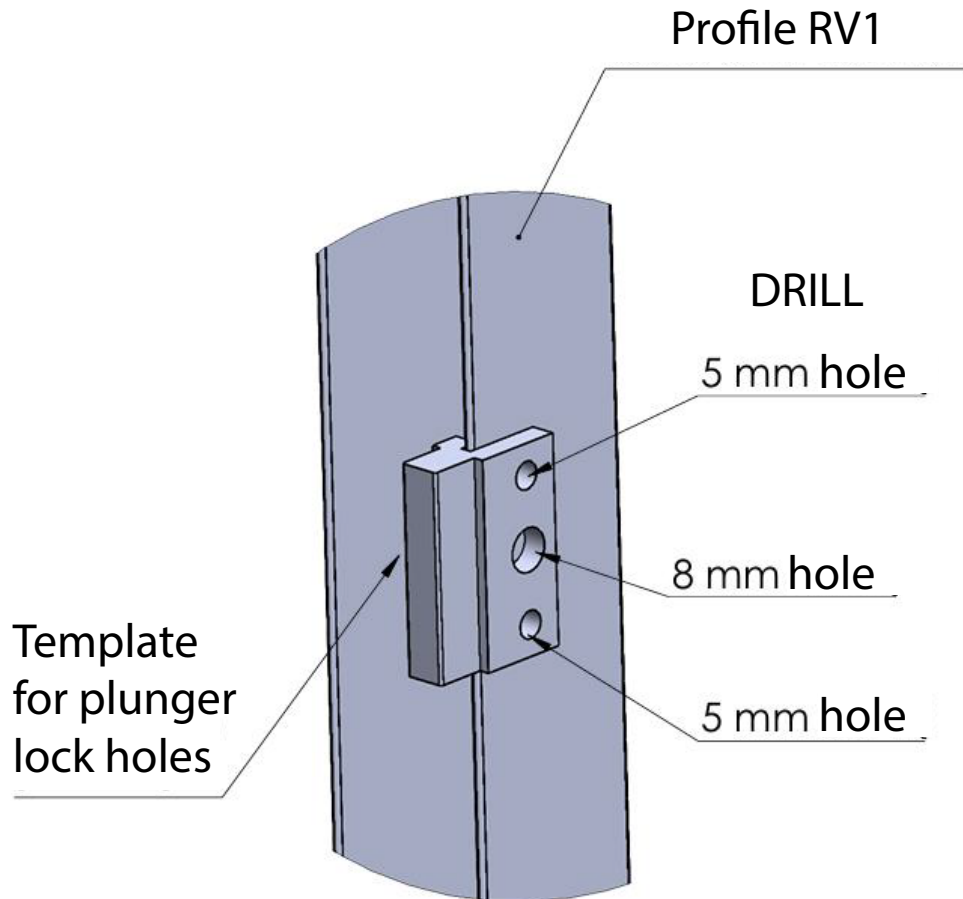

With the holes pre-drilled, we push the sliding sash against the side profile RV1 and drill a 12 mm hole. Then insert the bushing into that hole.



The plunger consists of:



Installed plunger:



In each vertical profile goes 2 rubbers which are screwed with M4,8x32 self-tapping screws.

